

MMW8 MAJOR WINCH

ASSEMBLY

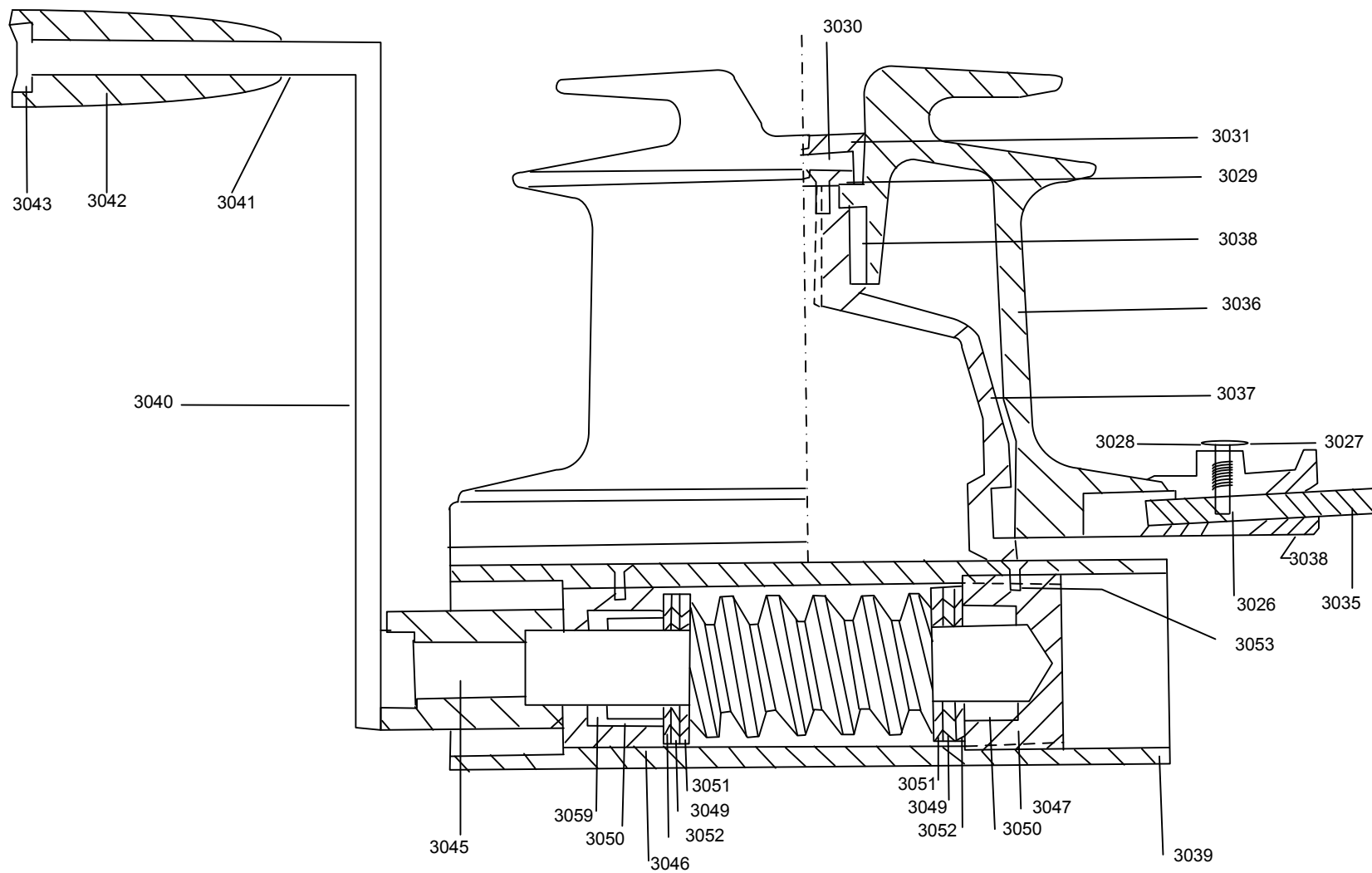

SCALE: FS

DATE: 4-8-69

DRAWN:

MURRAY DIVISION

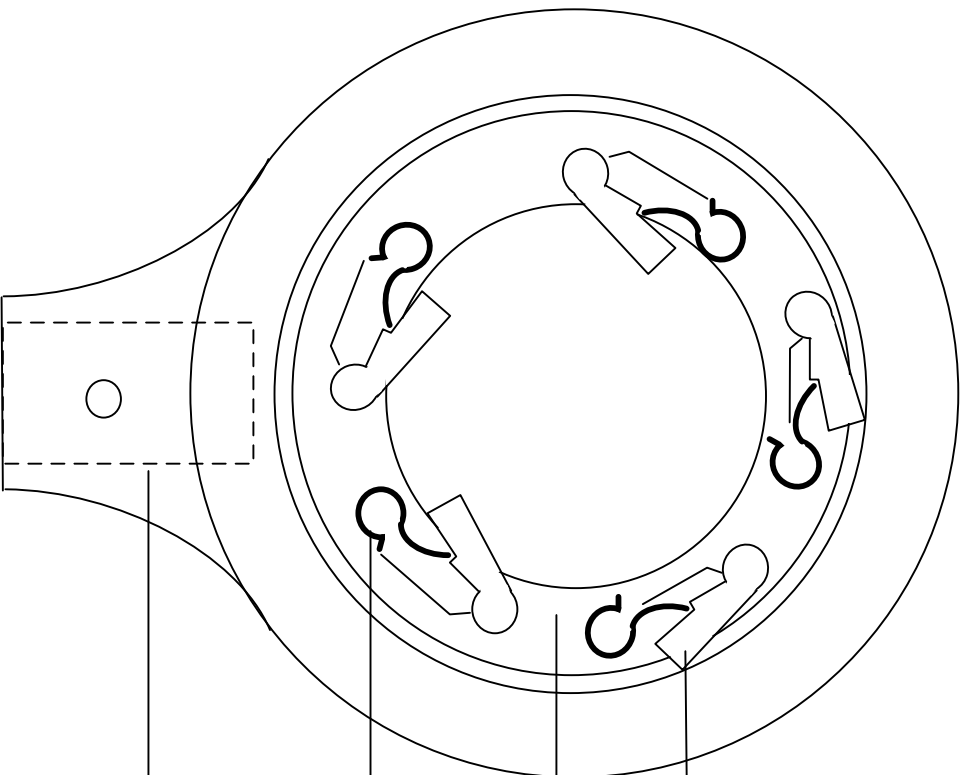

3059	O-Ring ARP210	1		Rubber
3058	Bearing WJ182112	1		
3057	Pawls	5		AB
3056	Spring - Pawl	5		PB
3055	Cover Plate	1		MB
3053	Lock Screw 1/4 x 3/8	2		SS
3052	Thrust Washer	2		SS
3051	Thrust Washer 1/8	2		SS
3050	Bearing B128	2		
3049	Bearing NTA 1220	2		
3048	Worm Wheel Screw	5		SS
3047	Bearing House Open	1		TB
3046	Bearing House Open	1		TB
3045	Worm	1		SS
3044	Worm Wheel	1		PB
3043	Nut	1		SS
3042	Gear Handle Grip	1		Mastic
3041	Gear Handle Pin	1		SS
3040	Gear Handle	1		MB
3039	Gear Base	1		MB
3038	Ratchet	1		MB
3037	Cone	1		MB
3036	Drum	1		MB
3031	Cap	1		TB
PART	NAME	N°		MAT'L

3035	Handle, ratchet	1		NAB
3030	Lockscrew	1		SS
3029	Cone Screw	1		TB
3028	Spring Cap	1		TB
3027	Spring Pin	1		TB
3026	Spring	1		PB
3025	Cover Screw 1/4 x 3/8	8		SS
PART	NAME	N°		MAT'L

CLEVECO